

# High Frequency Portable X-ray Unit

# PORTA100 HF



We proudly release the small sized and light weighted monobloc model, still having a high output by the improved 2 kW inverter system together with the x-ray tube of 20 kHU.

## FEATURES

- High output of Max. 100 kV and Max. 30 mA is obtained by the 2kW inverter system.
- Size  
Approximately 8.8 kg or 19.4 lbs  
160 mm(H) x 161 mm(W) x 291 mm(L) or 6.29 in(H) x 6.33 in(W) x 11.45 in(L)
- KV and mAs selectors adopted a rotary switch system for easy and quick selection of kV and mAs.
- APR switch stores 8 examination parts and corresponding exposure data (kV/mAs) in order to avoid an annoyance from referring these data to the radiographic chart every time.
- Modular connector for DR system compatibility. (8P RJ-45)
- Automatic mAs control technique keeps always a real kV selected on the panel in order to obtain an expected film result even at the place where a certain drop of the line voltage occurs by the high impedance such as from the use of an extremely long extension cable.

**Rating:** 30 mA/40-66 kV/0.3-20 mAs  
20 mA/68-100 kV/0.3-20 mAs

**SPECIFICATIONS**

<b>Generator</b>	Inverter control type, 2 kW output
<b>kV setting</b>	40-100 kV (in 2 kV step). Rotary switch for digital display with 7 segment LED.
<b>mAs selection</b>	0.3-20 mAs (32 settings) 0.3, 0.4, 0.5, 0.6, 0.7, 0.8, 0.9, 1.0, 1.1, 1.2, 1.3, 1.4, 1.5, 1.6, 1.7, 1.8, 1.9, 2.0, 2.2, 2.5, 2.8, 3.2, 4.0, 5.0, 6.4, 7.0, 8.0, 9.0, 10, 12, 16, 20 mAs
<b>X-ray tube</b>	a) Focal spot: 1.2 x 1.2 mm b) Anode heat storage capacity: 20 kHU c) Target angle: 16 degrees
<b>Total filtration</b>	2.5 mm Al eq. at 100 kV
<b>Collimator</b>	A field lamp with a 30 sec. timer and cross indication line. A crossing point of 2 laser beams makes it easy to confirm a center of a radiographic field and exact SID even under the sunlight.
<b>Line cable</b>	6 meter long.
<b>Hand switch</b>	Two stage, deadman type with curled cable. (3 meter long at full extension)
<b>Net weight (Approximately)</b>	X-ray unit: 8.8 kg or 19.4 lbs Carrying case: 4 kg or 8.8 lbs
<b>Line voltage adjustment</b>	Automatic
<b>Power requirement</b>	100-120 V/30A or 200-240 V/16 A
<b>Power capacity</b>	115 V/35 A, 220 V/20 A, 240 V/18 A

SPECIFICATION &amp; DESIGN ARE SUBJECT TO CHANGE WITHOUT NOTICE.

**DRAWING**

UNIT:mm

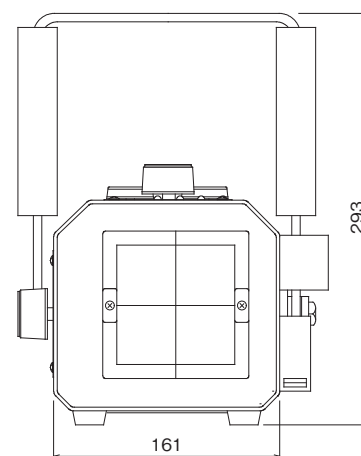

FRONT

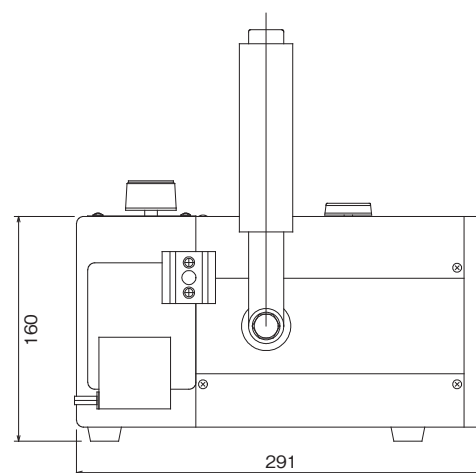

SIDE

Made in Japan